

高智慧科技 LED 规格书

SPECIFICATION FOR VANTEX LED LAMP

产品型号:

MODEL No : VA3528YYC3301A

制作日期: 2011 年 8 月 15 日

DOC. No : 15Aug2011

产品描述:

Product Description:

3528 黄色 SMT-LED

3.5 x 2.8 x 1.9mm SMT-LED in Yellow Color

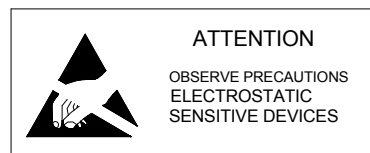

Applications:(应用)

- Indicators (指示灯)
- Illumination (照明)
- LED Back Lights (背光源)
- Energy Saving Lamp (节能灯)
- Automobile's Applications (汽车行业应用)

Absolute Maximum Ratings at Ta = 25°C

(在 25°C环境下最大绝对额定值)

Items (项目)	Symbol (符号)	Absolute maximum Rating (最大绝对额定值)	Unit (单位)
Forward Current (正向电流)	I_F	40	mA
Peak Forward Current (正向峰值电流)	I_{FP}	3x40	mA
Reverse Voltage (反向电压)	V_R	5	V
Power Dissipation (功率消耗)	P_D	2x48	mW
Operation (工作温度)	T_{opr}	-40 ~ + 100	°C
Storage Temperature (储存温度)	T_{stg}	-40 ~ + 100	°C
Junction temperature (结温)	T_j	120	°C
Soldering temperature (焊接温度)	T_{sol}	260	°C
Manual soldering time at 260°C(max) (260°C 手工焊接时间)	---	5	sec

Dimension Drawing

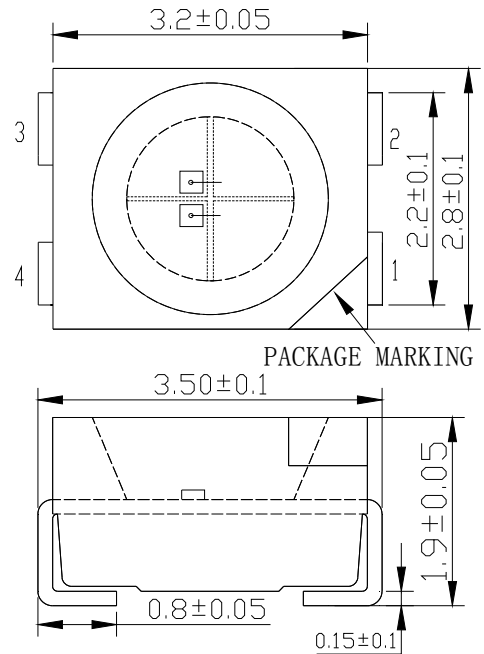

PIN Distribution:

+3<PIN> —|> — -2<PIN>

+4<PIN> —|> — -1<PIN>

1: Cathode Yellow

2: Cathode Yellow

3: Anode Yellow

4: Anode Yellow

Notes:

1. Proper current rating must be observed to maintain junction temperature below the maximum at all time.
(额定电流值要维持在最大结温温度以下.)
2. IFM condition: 0.1 ms pulse width, Duty Cycle=0.25.
(电流条件: 脉宽: 0.1ms, 周期: 0.25.)
3. All above test condition: Mounted on PC Board FR 4(pad size \geq 16mm²)
(以上测试条件: 安装在 FR4-PC 板上, 面积不能小于 16 平方毫米.)
4. LED lamps are not designed to be driven in reverse bias.
(LED 不能设计反偏驱动.)

Typical Electrical & Optical Characteristics (Ta = 25°C) (在 25°C 环境下光电强特性)

Items (项目)	Symbol (符号)	Condition (条件)	Min (最小值)	Typ (典型值)	Max (最大值)	Unit (单位)
Forward Voltage (正向电压)	V_F	$I_F = 40\text{mA}$	1.8	2.1	2.4	V
Reverse Current (反向漏电流)	I_R	$V_R = 5\text{V}$	---	---	5	μA
Luminous Intensity (光强)	I_v	$I_F = 40\text{mA}$	400	1200	2000	mcd
Luminous Flux (光通量)	Φ_v	$I_F = 40\text{mA}$	---	4.2	6.5	lm
Dominant Wavelength (波长)	λ_D	$I_F = 40\text{mA}$	585	590	595	nm
Power (Avg) (功率消耗)	P	$I_F = 40\text{mA}$	---	0.042	---	w
50% Power Angle (发光角度)	2 $\theta_{\frac{1}{2}}$	$I_F = 40\text{mA}$	---	120	---	deg

Notes:

- 1) Tolerance of measurement of V_f is ± 0.05 . (电压精度 ± 0.05)
- 2) Luminous Intensity is measured with the accuracy of $\pm 10\%$. (亮度测量精度 $\pm 10\%$.)

Graphs (曲线图)

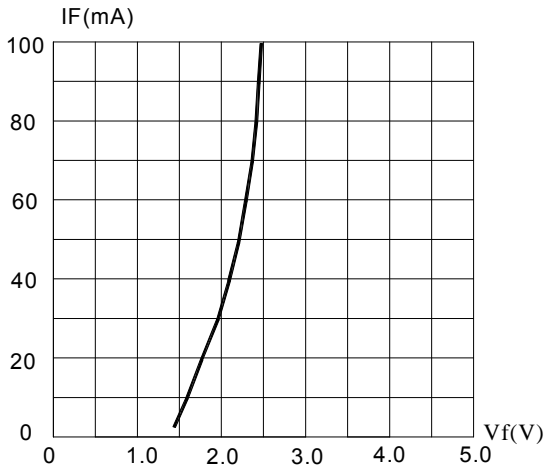

FIG.1 FORWARD CURRENT VS. FORWARD VOLTAGE.
(正向电流与正向电压的曲线图)

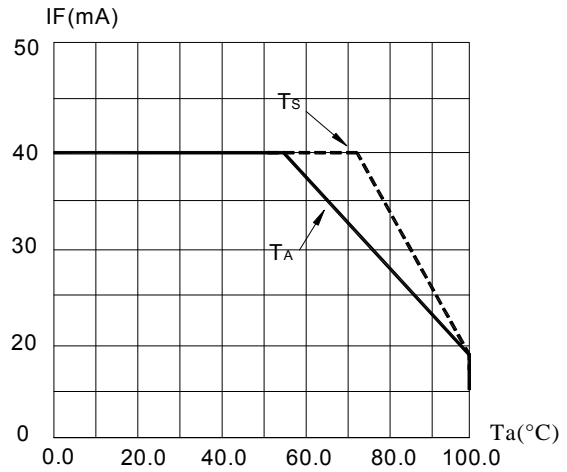

FIG.2 MAXIMUM FORWARD DC CURRENT VS AMBIENT TEMPERATURE($T_{jmax}=120\text{ }^{\circ}\text{C}$)
 T_A temp .ambient; T_s temp. solder piont.
(最大正向电流与环境温度关系曲线图)

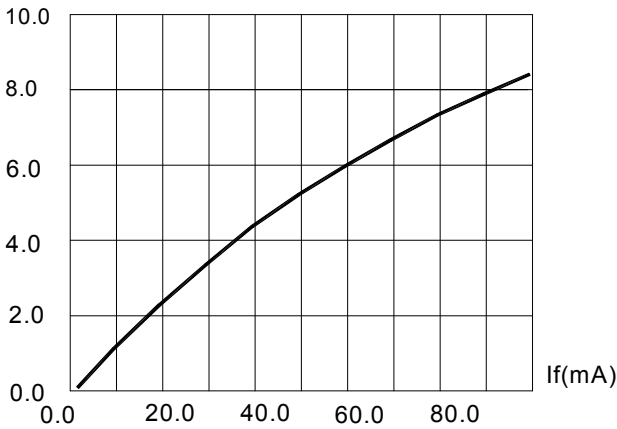
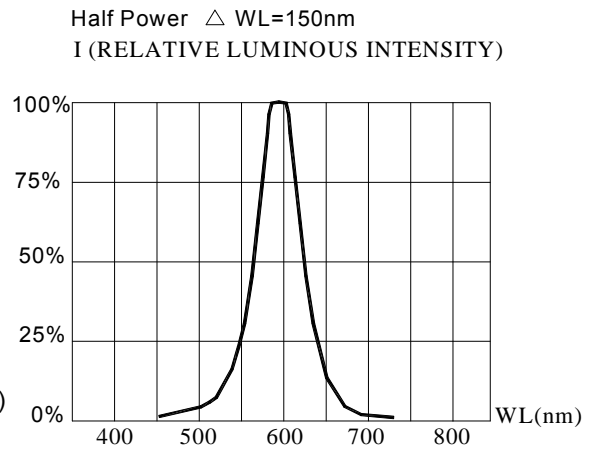
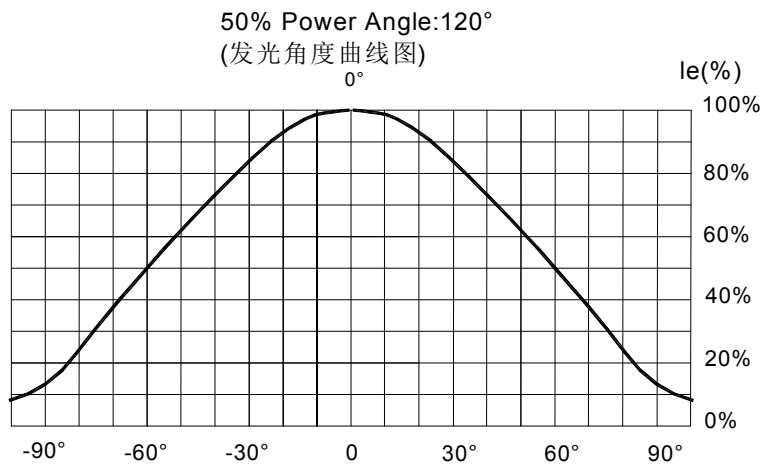

FIG.3 RELATIVE LUMINOUS INTENSITY VS. FORWARD CURRENT
(正向电流与光通量的曲线图)



Half Power $\Delta WL=150\text{nm}$
I (RELATIVE LUMINOUS INTENSITY)
FIG.4 RELATIVE LUMINOUS INTENSITY VS. WAVELENGTH.
(光谱曲线图)



50% Power Angle:120°
(发光角度曲线图)
FIG.5 FAR FIELD PATTERN

MODEL No :	VA3528YYYYC3301A
Edition No.	A0

Packaging (包装)

Dimensions for Tape (编带规格)

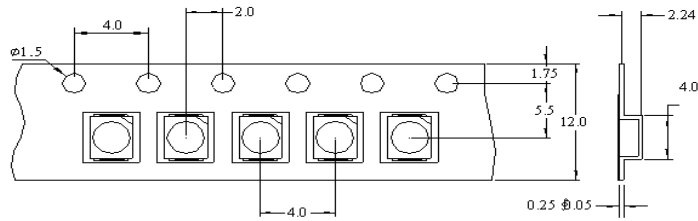

Packing (包装)

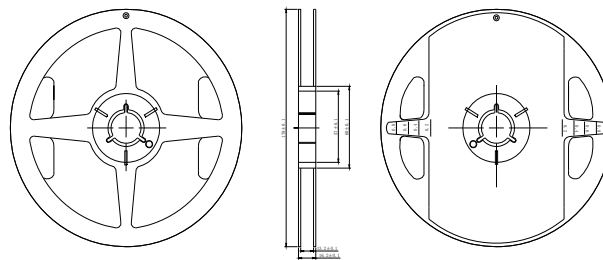

Reel, quantity: 2,000 pcs

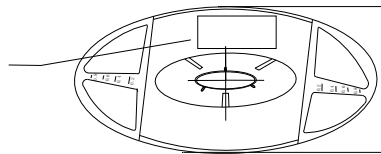

Bag, quantity: 2,000 pcs

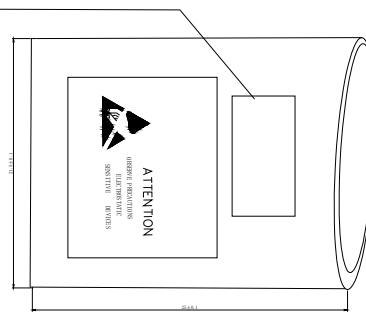

Box, quantity: 30 Bag

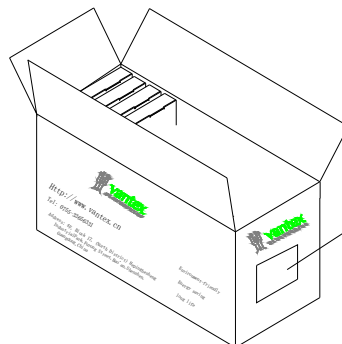

Notes:

- All dimensions are in mm, tolerance is $\pm 2.0\text{mm}$ unless otherwise noted.
(所有的尺寸都是毫米为单位, 公差 $\pm 2.0\text{mm}$, 特殊尺寸做特殊标识.)
- Specifications are not subject to change without notice.
(没有通知前说明书不能随意改动.)

Reliability Testing for SMD (可靠性测试)

Type (类型)	Test Item (测试项目)	REF. Standard (检测标准)	Test condition (测试条件)	Times (次数)	Sample count (样品数量)
Environments Sequence (环境检测)	Temperature Cycle (温度循环)	JESD22-A104-A	-40℃~25℃~100℃~25℃ 30min,5min,30min,5min	100 cycles	100
	Thermal shock (冷热冲击)	JESD22-A106	-40℃~100℃ 30min,30min	100 cycles	100
	Temperature Storage (温度存储)	JIS C 7021 (1977)B-11	Ta=60℃ RH=90%	1000Hrs	100
Operation Sequence (性能检测)	Life test (寿命测试)	JESD22-A108-A	Ta=25℃ If: B=20mA	1000Hrs	100
	High humidity Heat life test (高温高湿寿命测试)	JESD22-A101	Ta =85℃ RH=85% If: B=15mA	1000Hrs	100
Destructive Sequence (破坏性检测)	Resistance to soldering Heat (高温焊接)	JESD22-A113	IR soldering 245℃/10sec	10Sec	20
ESD Test (抗静电测试)	ESD TEST	AEC(Q101-002)	Human body model 2000v	--	10
Physical Sequent (抗振性检测)	Physical Sequence	MIL-STD-883 Method 2007	20G min ,20 to 2000Hz 4 cycles,4min.Each,X,Y,Z	--	50

Application notes (申请注意事项)

The purpose of this document is to provide a clear understanding to the customers and users, on the ways how to use our LED lamps appropriately. (该文件的目的是为了让客户和使用者更加清楚怎样使用我们 LED 产品.)

Description

Generally, LED can be used the same way as other general-purpose semiconductors. When using VANTEX'S Lamps, the following precautions must be taken to protect the LED.(LED 都有共同的特性, 使用我们高智慧 LED 产品也要做到以下保护措施.)

1. Cleaning (清洁)

- ✧ Don't use unspecified chemical liquids to clean the SMT-LED; the chemical could harm the SMT-LED. When washing is necessary, please immerse the SMT-LED in alcohol at normal room temperature for less than 1 minute and dry at normal room temperature for 15 minutes before use. (不要使用未经许可的化学清洗液清洗 LED, 化学品会损害 LED, 若必须清洗时, 请在室温下使用标准认证的酒精清洗, 清洗时间不能超过 1 分钟, 使用前在干燥的房间内放置 15 分钟.)
- ✧ The influence of ultrasonic cleaning on the SMT-LED depending on factors such as ultrasonic power and the way SMT-LED are mounted. Ultrasonic cleaning shall be pre-qualified to ensure this will not cause damage to the SMT-LED. (超声波震动清洗对 LED 是有损害的, 所以使用超声波清洗后要对产品再次确认对产品是没有损害的.)

2. Moisture Proof Packing (防潮)

- ✧ In order to prevent moisture absorption into SMT-LED during the transportation and storage, SMT-LED is packed in a moisture barrier bag. Desiccants and a humidity indicator are packed together with SMT-LED as the secondary protection. The indication of humidity indicator card provides the information of humidity within SMD packing. (为了防止 LED 在运输和储存的过程中受潮, 所以把 LED 包装在一个抽真空的铝箔袋里, 在铝箔袋里放一个干燥剂和一个湿度卡作为进一步防护,)

3. Storage (储存)

- ✧ Shelf life in original sealed bag at storage condition of $<40^{\circ}\text{C}$ and $<90\%RH$ is 6 months. Baking is required whenever shelf life is expired. (在温度低于 40°C 和湿度低于 90% 的环境下质保期是 6 个月, 质保期过后必须烘烤后使用.)
- ✧ After bag opening, the SMT-LED must be stored under the condition $<30^{\circ}\text{C}$ and $<60\%RH$. Under this condition, SMT-LED must be used (subject to reflow) within 8 hours after bag opening, and re-baking is required when exceeding 12 hours. (打开包装袋后, LED 必须在温度低于 30°C 、湿度低于 60% 的条件下保存, 打开包装袋的 LED 灯必须在 8 小时内使用完成, 未使用完的 LED 灯必须从新标准条件烘烤 12 小时后在使用.)
- ✧ For baking, place SMT-LED in oven at temperature $80\pm 5^{\circ}\text{C}$ and relative humidity $\leq 10\%RH$, for 12 hours. (LED 除湿条件是烤箱温度 $80\pm 5^{\circ}\text{C}$ 、湿度低于 10% , 除湿时间 12 小时.)

4. Soldering (焊接)

. Manual soldering by soldering iron (手工烙铁焊接)

- ✧ The use of a soldering iron of less than 25W is recommended and the temperature of the iron must be kept at below 315°C , with soldering time within 2 seconds. (建议使用低于 25 瓦以下的烙铁, 烙铁温度低于 315°C , 焊接时间控制在 2 秒以内.)
- ✧ The silicone sealant of SMT-LED should not be in contact with tip of soldering iron. (烙铁头上的松香类杂物不要接触到 LED 表面的硅胶.)
- ✧ No mechanical stress should be exerted on the resin portion of SMT-LED during soldering. (LED 焊接过程中不能有外物挤压 LED 表面硅胶.)
- ✧ Handling of SMT-LED should be done when the package has been cooled down to below 40°C or less. This is to prevent the SMT-LED failures due to thermal-mechanical stress during handling. (为了防止高温下 LED 受机械压力的破坏, 所以 LED 必须冷却温度低于 40°C 以下才能进行包装,)

. Reflow Soldering (回流焊)

- ✧ Recommended solder pad design for heat dissipation (Unit: mm) (为了更好的散热, 建议根据以下焊接图设计具体产品.)

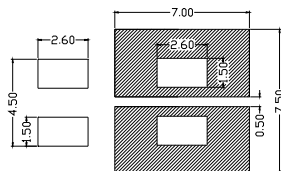

- ✧ The temperature (Top surface of SMT-LED) profile is as below: (以下是 LED 回流焊焊接温度曲线图.)

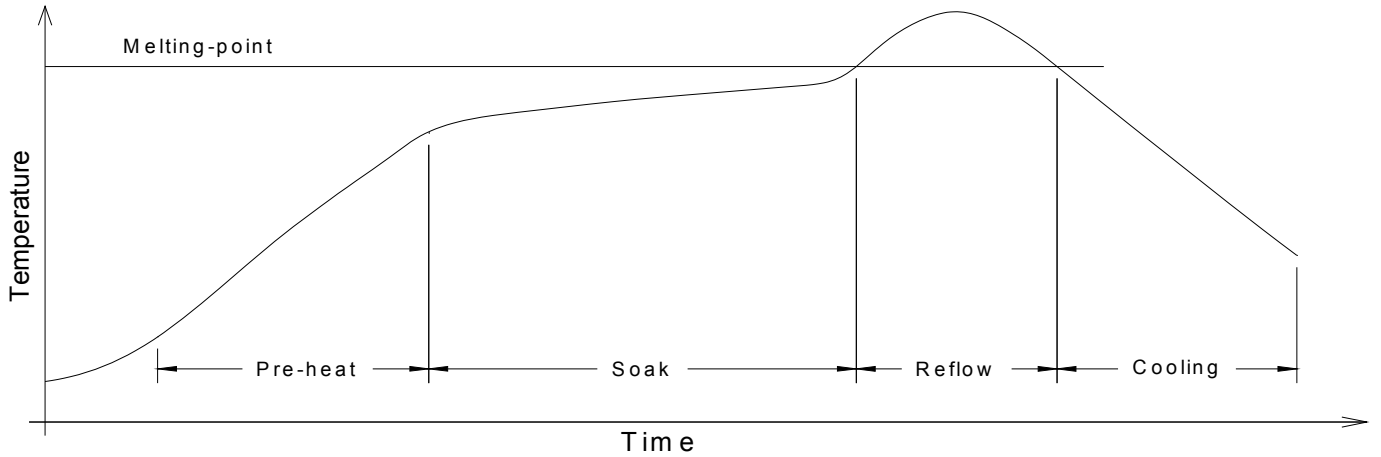

Solder = Sn63-Pb37 (有铅锡膏焊接)	Solder =Low Lead-free (无铅锡膏焊接)
Average ramp-up rate = 4°C/s max. (温度上升斜率最大是 4 °C/s)	Average ramp-up rate = 3°C/s max. (温度上升斜率最大是 3 °C/s)
Preheat temperature = 100°C ~150°C (预热温度)	Preheat temperature = 130°C ~170°C (预热温度)
Preheat time = 100s max. (预热最长时间)	Preheat time = 120s max. (预热最长时间)
Ramp-down rate = 6°C/s max. (上升斜率最大是 6 °C/s)	Ramp-down rate = 6°C/s max. (上升斜率最大是 6 °C/s)
Peak temperature = 220°C max. (峰值温度最大是 220 °C)	Peak temperature = 240°C max. (峰值温度最大是 240 °C)
Time within 5°C of actual Peak Temperature = 10s max. (峰值温度精度±5°C, 时间最长 10 秒.)	Time within 3°C of actual Peak Temperature = 25s max. (峰值温度精度±3°C, 时间最长 25 秒.)
Duration above 180°C is 80s max. (180 °C 以上时间是最长 80 秒.)	Duration above 200°C is 40s max. (200 °C 以上时间是最长 40 秒.)

- ✧ Modification is not recommended on SMT-LED after soldering. If modification cannot be avoided, the modifications must be pre-qualified to avoid damaging SMT-LED. (请参考以上焊接参数, 若必须改变焊接参数, 必须确保修改后不损害 LED 寿命.)
- ✧ Reflow soldering should not be done more than one time. (不能多次过回流焊.)
- ✧ No stress should be exerted on the package during soldering. (焊接过程中不能有外物挤压 LED.)
- ✧ PCB should not be wrapped after soldering; this is to allow natural cooling of the PCB board and SMT-LED. (过回流焊后 PCB 板不能立即包装, 必须等到冷却后才能包装.)

5. Electrostatic Discharge and Surge current (静电和浪涌电流)

- ✧ Electrostatic discharge (ESD) or surge current (EOS) may damage SMT-LED. (静电和浪涌电流都会对 LED 造成损害.)
- ✧ Precautions such as ESD wrist strap, ESD shoe strap or antistatic gloves must be worn whenever handling of SMT-LED.
(使用 LED 的时候, 必须穿防静电衣服、静电鞋、戴有线静电环预防静电损坏 LED)
- ✧ All devices, equipment and machinery must be properly grounded. (使用的设备和工具必须接好地线消除静电.)
- ✧ It is recommended to perform electrical test to screen out ESD failures at final inspection. (要对 LED 进行最后 ESD 失效性检测.)
- ✧ It is important to eliminate the possibility of surge current during circuitry design. (电路必须设计浪涌电流保护电路.)

6. Heat Management (温度控制)

- ✧ Heat management of SMT-LED must be taken into consideration during the design stage of SMT-LED application. The current should be de-rated appropriately by referring to the de-rating curve attached on each product specification.
(LED 使用设计期间必须考虑热量的散热情况, 驱动电流的大小需参考说明书上的数值选择合适的电流.)