

FS7M0880

Fairchild Power Switch(FPS)

Features

- Precision Fixed Operating Frequency
- FS7M0880(66kHz)
- Pulse By Pulse Over Current Limiting
- Over Load Protection
- Over Voltage Protection (Min. 25V)
- Internal Thermal Shutdown Function
- Under Voltage Lockout
- Internal High Voltage Sense FET
- Latch Up Mode
- Soft Start

Description

The Fairchild Power Switch(FPS) product family is specially designed for an off line SMPS with minimal external components. The Fairchild Power Switch(FPS) consists of a high voltage power SenseFET and the current mode PWM controller IC. The PWM controller includes an integrated fixed oscillator, the under voltage lock out, the leading edge blanking block, the optimized gate turn-on/turn-off driver, the thermal shut down protection, the over voltage protection, the temperature compensated precision current sources for loop compensation and an fault protection circuit. Compared to just PWM controller combined MosFET or RCC switching converter solution, a Fairchild Power Switch(FPS) can reduce total component price, design size, and weight,also simultaneously increase efficiency, productivity, and system reliability. It has a simple method of application well suited for cost down design in either a flyback converter or a forward converter.



Internal Block Diagram

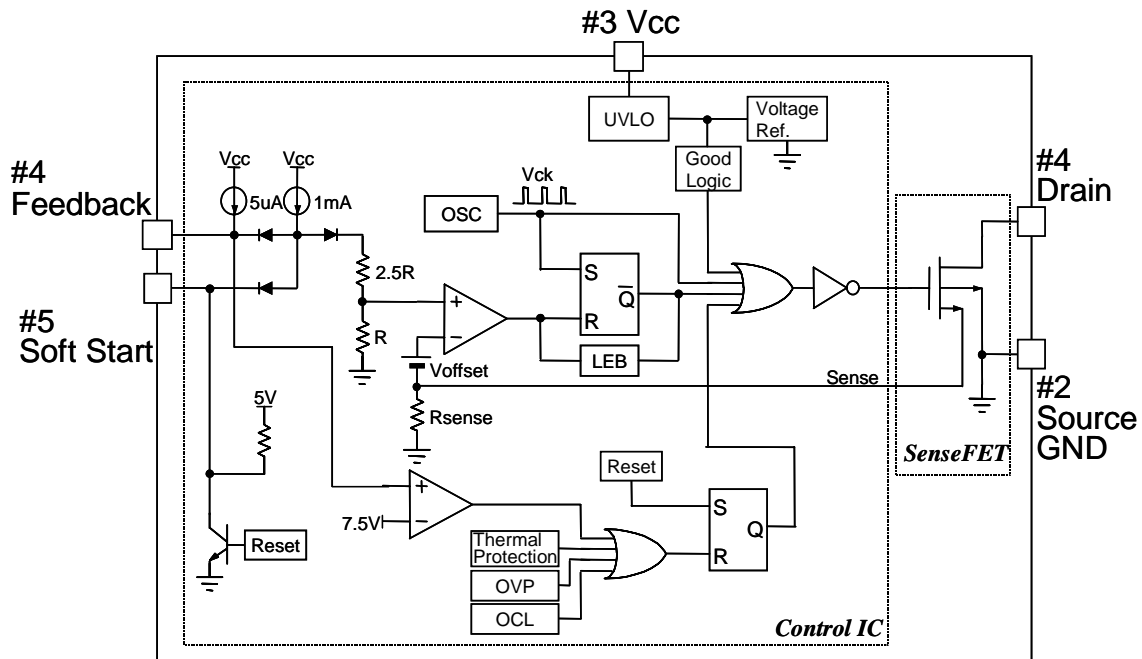

Rev.1.0.1

Absolute Maximum Ratings

Parameter	Symbol	Value	Unit
Drain-Gate Voltage ($R_{GS}=1M\Omega$)	VDGR	800	V
Gate-Source (GND) Voltage	VGS	± 30	V
Drain Current Pulsed ⁽²⁾	IDM	32.0	ADC
Single Pulsed Avalanche Energy ⁽³⁾	EAS	810	mJ
Avalanche Current ⁽⁴⁾	IAS	15	A
Continuous Drain Current ($T_C=25^\circ\text{C}$)	ID	8.0	ADC
Continuous Drain Current ($T_C=100^\circ\text{C}$)	ID	5.6	ADC
Maximum Supply Voltage	VCC,MAX	30	V
Input Voltage Range	VFB	-0.3 to VSD	V
Total Power Dissipation	PD	190	W
	Derating	1.54	W/ $^\circ\text{C}$
Operating Ambient Temperature	TA	-25 to +85	$^\circ\text{C}$
Storage Temperature	TSTG	-55 to +150	$^\circ\text{C}$

Note:

1. $T_j = 25^\circ\text{C}$ to 150°C
2. Repetitive rating: Pulse width limited by maximum junction temperature
3. $L = 24\text{mH}$, $V_{DD} = 50\text{V}$, $R_G = 25\Omega$, starting $T_j = 25^\circ\text{C}$
4. $L = 13\mu\text{H}$, starting $T_j = 25^\circ\text{C}$

Electrical Characteristics (SFET part)

(Ta=25°C unless otherwise specified)

Parameter	Symbol	Condition	Min.	Typ.	Max.	Unit
Drain-Source Breakdown Voltage	BVDSS	VGS=0V, ID=50μA	800	-	-	V
Zero Gate Voltage Drain Current	IDSS	VDS=Max., Rating, VGS=0V	-	-	50	μA
		VDS=0.8Max., Rating, VGS=0V, TC=125°C	-	-	200	μA
Static Drain-Source On Resistance ^(note1)	RDS(ON)	VGS=10V, ID=5.0A	-	1.2	1.5	Ω
Forward Transconductance ^(note1)	gfs	VDS=15V, ID=5.0A	1.5	2.5	-	S
Input Capacitance	Ciss	VGS=0V, VDS=25V, f=1MHz	-	2460	-	pF
Output Capacitance	Coss		-	210	-	
Reverse Transfer Capacitance	Crss		-	64	-	
Turn On Delay Time	td(on)	VDD=0.5BVDSS, ID=8.0A (MOSFET switching time are essentially independent of operating temperature)	-	-	90	nS
Rise Time	tr		-	95	200	
Turn Off Delay Time	td(off)		-	150	450	
Fall Time	tf		-	60	150	
Total Gate Charge (Gate-Source+Gate-Drain)	Qg	VGS=10V, ID=8.0A, VDS=0.5BVDSS (MOSFET switching time are essentially independent of operating temperature)	-	-	150	nC
Gate-Source Charge	Qgs		-	20	-	
Gate-Drain (Miller) Charge	Qgd		-	70	-	

Note:

1. Pulse test: Pulse width ≤ 300μS, duty cycle ≤ 2%

2. $S = \frac{1}{R}$

Electrical Characteristics (CONTROL part) (Continued)

(Ta=25°C unless otherwise specified)

Parameter	Symbol	Condition	Min.	Typ.	Max.	Unit
UVLO SECTION						
Start Threshold Voltage	VSTART	-	14	15	16	V
Stop Threshold Voltage	VSTOP	After turn on	8	9	10	V
OSCILLATOR SECTION						
Initial Frequency	FOSC	-	60	66	72	kHz
Frequency Change With Temperature ⁽²⁾	$\Delta F/\Delta T$	$-25^{\circ}\text{C} \leq T_a \leq +85^{\circ}\text{C}$	-	± 5	± 10	%
Maximum Duty Cycle	Dmax	-	45	50	55	%
FEEDBACK SECTION						
Feedback Source Current	I _{FB}	Ta=25°C, 0V ≤ V _{fb} ≤ 3V	0.7	0.9	1.1	mA
Shutdown Delay Current	I _{delay}	Ta=25°C, 5V ≤ V _{fb} ≤ V _{SD}	4.0	5.0	6.0	μA
SOFT START SECTION						
Soft Start Voltage	V _{SS}	V _{FB} = 2V	4.7	5.0	5.3	V
Soft Start Current	I _{SS}	Sync & S/S=GND	0.8	1.0	1.2	mA
REFERENCE SECTION						
Output Voltage ⁽¹⁾	V _{ref}	Ta=25°C	4.80	5.00	5.20	V
Temperature Stability ⁽¹⁾⁽²⁾	V _{ref} /ΔT	$-25^{\circ}\text{C} \leq T_a \leq +85^{\circ}\text{C}$	-	0.3	0.6	mV/°C
CURRENT LIMIT (SELT-PROTECTION)SECTION						
Peak Current Limit	I _{OVER}	Max. inductor current	4.40	5.00	5.60	A
PROTECTION SECTION						
Thermal Shutdown Temperature (T _j) ⁽¹⁾	T _{SD}	-	140			°C
Over Voltage Protection Voltage	V _{OV}	-	25	28	31	V
Over Current Protection Voltage	V _{OC}	-	1.05	1.10	1.15	V
TOTAL DEVICE SECTION						
Start Up Current	I _{START}	V _{CC} =14V	-	40	80	μA
Operating Supply Current (Control Part Only)	I _{OP}	Ta=25°C	-	8	12	mA
	I _{op(lat)}	After latch, V _{cc} =V _{stop} -0.1V	150	250	350	μA
Shutdown Feedback Voltage	V _{SD}	-	6.9	7.5	8.1	V

Note:

1. These parameters, although guaranteed, are not 100% tested in production
2. These parameters, although guaranteed, are tested in EDS (wafer test) process

Block Diagram

It can be divided into several large, functional sections: under voltage lockout circuitry (UVLO); reference voltage; oscillator (OSC); pulse width modulation (PWM) block; protection circuits; and gate driving circuits.

Start Up

Input voltage range: 85 ~ 265 V (AC)

When Vac is minimum and it is started by the DC Link bulk capacitor, the starting resistance is calculated as follows:

$$R_{start} = \frac{85\sqrt{2} - 15}{80\mu A} = 1.3M\Omega$$

When Vac is maximum and it is started by the DC Link Bulk capacitor, the power loss is calculated as follows:

$$P_{loss} = \frac{(265\sqrt{2} - 15)^2}{1.3M\Omega} = 0.1(W)$$

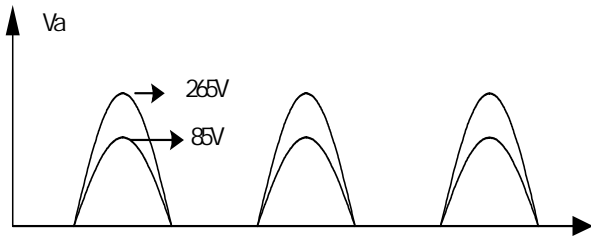

When it is started by the one-phase of the AC-Lines and Vac is minimum, the starting resistance is calculated as follows:

$$R_{Start} = \frac{2 \cdot 85\sqrt{2} - 15\pi}{2\pi} \div (80\mu A) = 38M\Omega$$

When it is started by the one-phase of the AC_Line and Vac is maximum, the power loss is calculated as follows:

$$V_{a(rms)} = \sqrt{\frac{1}{2\pi} \int_0^\pi (V_p \sin t - 15)^2 dt} = 177V (V_p = 265\sqrt{2})$$

$$P_{loss} = \frac{V_{a(rms)}^2}{R_{start}} = \frac{(177)^2}{38M} = 82(mW)$$

The starting current across the starting resistor charges the SPS VCC capacitor. When the VCC becomes greater than the starting voltage, the SPS starts to switch the built-in MOSFET. Once it starts, the current in the SPS control IC abruptly is increased to 7mA, makes it difficult to operate with the current through the starting resistor. Therefore, after it starts, the auxiliary winding of the transformer supplies most of the power to SPS. It is best to use an appropriate size VCC power capacitor, generally about 33μF, because if it is too large, the starting time can be delayed. This operation is

described in Fig 2. Although VCC only needs to be set above 9V during operation, it should be set such that OVP does not execute during an overload condition. For a full load, about 18~20V is appropriate for the VCC voltage and for no load, about 13~14V.

Protection

The FPS has several self-protection circuits, which can operate without additional external components, thereby acquiring reliability without increase in cost. After a protection circuit comes on, it can completely stop the SMPS until the cutoff AC power is reconnected (Latch Mode Protection) or it can make the SMPS operate above the UVLO by unlatching the control voltage below the ULVO (Auto Restart Mode Protection).

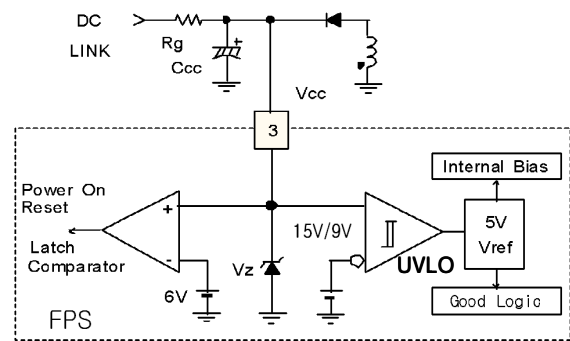

Figure 1. Detail of the undervoltage lockout (UVLO) circuitry in a Fairchild Power Switch. The gate operating circuit holds in a low state during UVL thereby maintaining the SenseFET at turnoff.

These two operations are user-command operations, so the user can select the operation from the IC or by carefully controlling circuit constants. The operation and applications for each protection are described below.

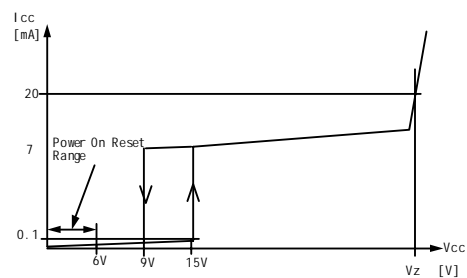

Figure 2. Start-up Waveform

Over Load Protection

In abnormal status of SMPS over load is distinguished from load short. This happens when a load exceeds a pre-set load during normal operation. That is, the FPS overload protection circuit stops the FPS if an instantaneous load increases and becomes greater than 50W during normal operation, when the maximum SMPS output had been pre-set to 30W. In this type of protection, the protection

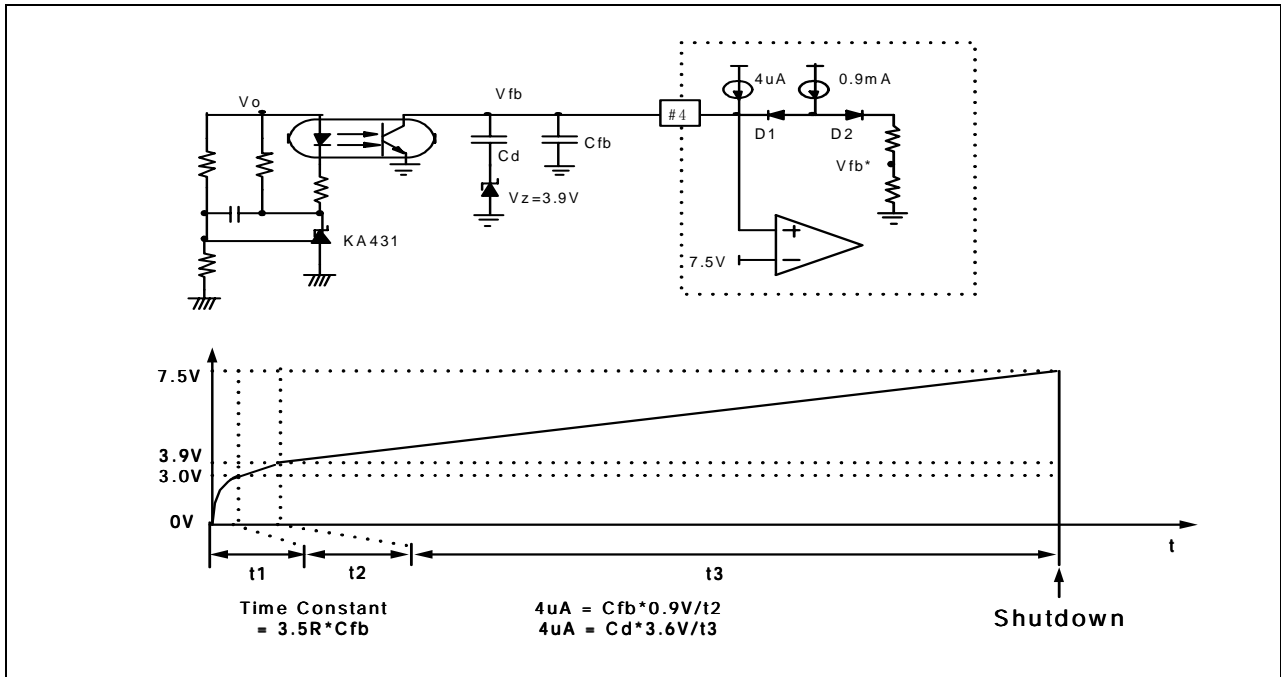

Figure 3. SPS Delayed Shutdown

circuit can perform undesired operations even during transient state, which lasts until normal operation. As a measure against this problem, this protection circuit in the SPS operates after a specified period to determine whether the condition is a transient or an overload. This is done to prevent protection circuit operation during a transient state, which returns normal after a specified period. This operation is described as follows.

Because the FPS uses the current control mode, it cannot flow current over the set maximum current, and therefore the maximum input power is restricted at the characteristic voltage. Therefore, if the output consumes beyond this maximum power, V_O , shown in the figure below, becomes less than the set voltage and only the provided minimum current can flow through KA431. As a result, the secondary current of the photocoupler becomes almost zero. If all the SPS's 0.9mA current source flows through the internal resistor ($2.5R + R = 3k$), V_{fb} becomes approximately 3V, and the 4uA current starts to charge C_{fb} . Because the photocoupler secondary current is almost zero, V_{fb} continues to increase until it reaches 7.5V, at which time the SPS shutsdown. The delay time to shutdown is the time required to charge C_{fb} to 4.5V with 4uA and can be easily set. When C_{fb} is 10nF(103), t_2 is approximately 11.2ms and when 0.1uF(104) approximately 120ms. With this amount of the SPS does not shutdown for most transient states. Just increasing C_{fb} to obtain a longer delay time can become a problem, because C_{fb} is an important parameter for determining the response speed (Dynamic Response) of the SMPS. Similarly, V_{fb} exceeds 3V and the 4uA current starts to charge the C_{fb} . At this time, V_{fb} continues to increase until it becomes 7.5V, at which time a resistor could be added between the F/B pin and GND to lengthen the time to

SPS shutdown. If a part of delay current go through the added resistor, the time to shutdown can be lengthened. In our test the delay shutdown time with C_{fb} (473) and resistor (3.9M) is about two times longer than with only C_{fb} (473). When V_{fb} is 7.5V, the current flowing through this 3.9mΩ resistor is approximately 1.9uA. To obtain the same results, if a zener diode (about 3.9 ~ 4.7V) in series connection with a capacitor is parallel-connected to C_{fb} , as depicted in Fig 3., the desired shutdown delay time could be obtained according to the size of the capacitor.

Over voltage Protection Circuit

The FPS has a self-protection feature against malfunctions, such as feedback circuit open or short-circuit. When the feedback terminal short circuits as seen from the primary side, the feedback terminal voltage becomes zero, and switching cannot start as a result. If the feedback terminal opens, then the protection circuit initiates as in the overload protection circuit. If the feedback terminal looks open due to a malfunction in the secondary side feedback circuit or a non-solder, the primary side continues to switch with the set maximum current until the protection circuit come on; therefore, it is normal for the secondary side voltage to become much greater than the rated voltage. If there was no protection circuit guarding against such conditions, the fuse can blow or, even more serious, a fire can start. Even if it does not lead such dire circumstances, the IC connected to the secondary side without a regulator could be destroyed (especially the digital IC such as TTL IC etc.) For such instances, time, the over voltage protection circuit (protection against feedback circuit abnormalities) starts to operate in the SPS. In such circumstances, the output voltage, which increases tremendously, is made proportional

to the SPS VCC voltage. If VCC exceeds 24 V, the SPS IC starts the protection circuit. Therefore, VCC should be appropriately kept below 24V during normal operation.

OCP (Over Current Protection)

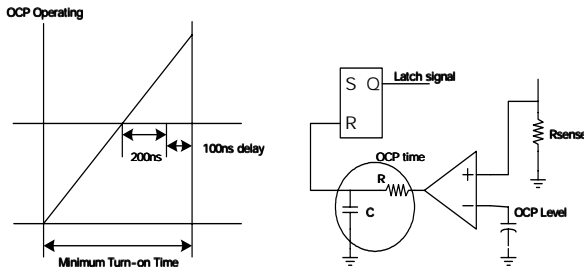

Figure 5. OCP Function & Block

The FPS has various built-in, basic protection features. They are the UVLO (Under Voltage Lock Out), OLP (Over Load Protection) and OCP (Over Current Protection). However, if a secondary side diode short or load short occur due to a worst case condition, such as a maximum input voltage

putting a large strain on the device, another external component may need to be added. By adding these requirements in the FPS, superior reliability and advantageous cost can be achieved.

When gate on signal of the SenseFet is received, simultaneously the OCP block senses Ipeak through the sense resistor for 1us. After the OCP block has turned on, the voltage across the resistor is compared to the pre-set voltage in the comparator, and, if it takes longer than 200ns within the allowed comparison time of 1us, then the comparator produces a high signal, which latches the OCP. fig 4. shows the OCP latch waveform. When there is a diode short/load short, the SPS turns on for the minimum turn-on time. If the instantaneous current is of the form shown in fig 4., the OCP block opens a 1us window to compare the voltage proportional to the current across the resistor with the reference voltage and latches. Here, the 100ns delay after the 200ns is the delay time to SenseFET gate off and is generated from the comparison of the voltage across the sense resistor.

Soft start operation

Normally, the SMPS output voltage increases from start up with a fixed time constant. This is due to the capacitive component of the load. At start up, therefore, the feedback signal applied to the PWM comparator's inverting input reaches its maximum value (1V), This is because the feedback loop is effectively open. Also at this time, the drain current is at its peak value (Ipeak) and maximum allowable power is being delivered to the secondary load. With that said, note that when the SMPS pushes maximum power to the secondary side for this initial fixed time, the

entire

circuit is seriously stressed. Use of a soft start function avoids such stresses. Figure 6 shows how to implement a soft start for a Fairchild Power Switch(FPS). At turn on, the soft start capacitor on pin 5 of the Fairchild Power Switch(FPS) starts to charge through the 1mA current source. When the voltage across CS reaches 3V, diode DS turns off. No more current flows to it from the 1mA current source. Cs then continues to charge to 5V through the 20kΩ resistor.

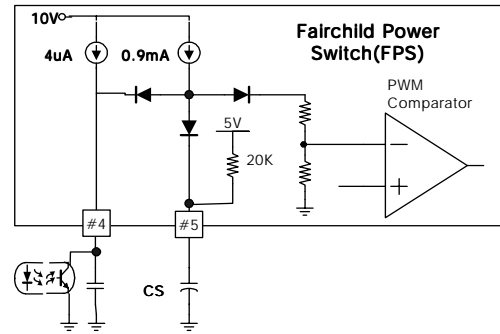
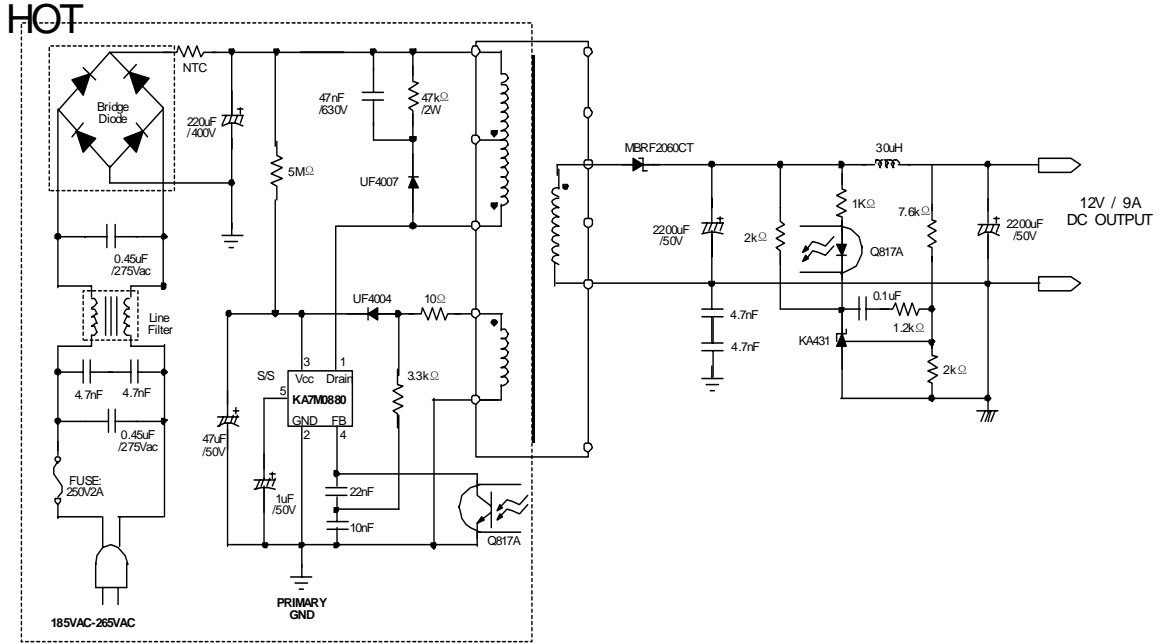

Figure 6. Soft Start Circuit.

Note that when the voltage across CS exceeds 3V, The voltage at the comparator's inverting terminal no longer follows the voltage across CS. Instead, it follows the output voltage feedback signal. In shutdown or protection circuit operation, capacitor CS is discharged, to enable it to charge from 0V at restart.

3. Application Note using the SPS -Flyback Application (100W)



Transformer Specification

2. Winding Specification

No.	PIN(S → F)	WIRE	TURNS	WINDING METHOD
NP/2	1 → 3	0.4 φ × 1	42	SOLENOID WINDING
INSULATION : POLYESTER TAPE t = 0.050mm, 1Layer				
N+12V	12 → 13	14mm × 1	8	COPPER WINDING
INSULATION : POLYESTER TAPE t = 0.050mm, 3Layer				
NB	8 → 7	0.3 φ × 1	9	SOLENOID WINDING
INSULATION : POLYESTER TAPE t = 0.050mm, 1Layer				
NP/2	3 → 4	0.4 φ × 1	42	SOLENOID WINDING
OUTER INSULATION : POLYESTER TAPE t = 0.050mm, 3Layer				

3. Electical Characteristic

CLOSURE	PIN	SPEC.	REMARKS
INDUCTANCE	1 - 4	700uH ±10%	1kHz, 1V
LEAKAGE L	1 - 4	10uH MAX.	2nd ALL SHORT

4. Core & Bobbin

CORE : EER 4042
BOBBIN : EER4042

-Forward Application (250W)

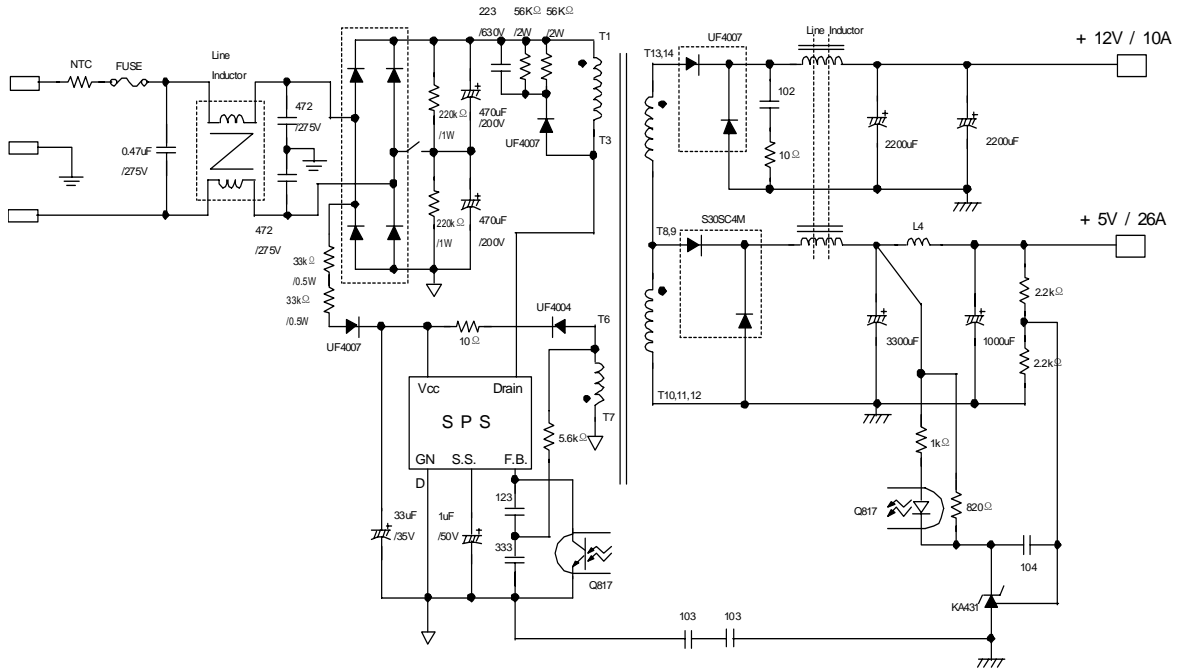

Transformer Specification

2. Winding Specification

No.	PIN(S → F)	WIRE	TURNS	WINDING METHOD
NP/2	1 → 3	0.65 φ × 1	50T	SOLENOID WINDING
N+5V	8, 9 → 10, 11, 12	14mm × 1	4T	COPPER WINDING
N+12V	13, 14 → 9	0.65 φ × 4	5T	SOLENOID WINDING
NP/2	1 → 3	0.65 φ × 1	50T	SOLENOID WINDING
NVCC	7 → 6	0.65 φ × 1	6T	SOLENOID WINDING

3. Electrical Characteristic

CLOSURE	PIN
INDUCTANCE	1 - 3
LEAKAGE L	1 - 3

4. Secondary Inductor(L2) Specification

Core : Power Core 27 φ 16 Grade

5V : 12T (1 φ × 2)

10V : 27T (1.2 φ × 1)

Package Dimensions

TO-3P-5L

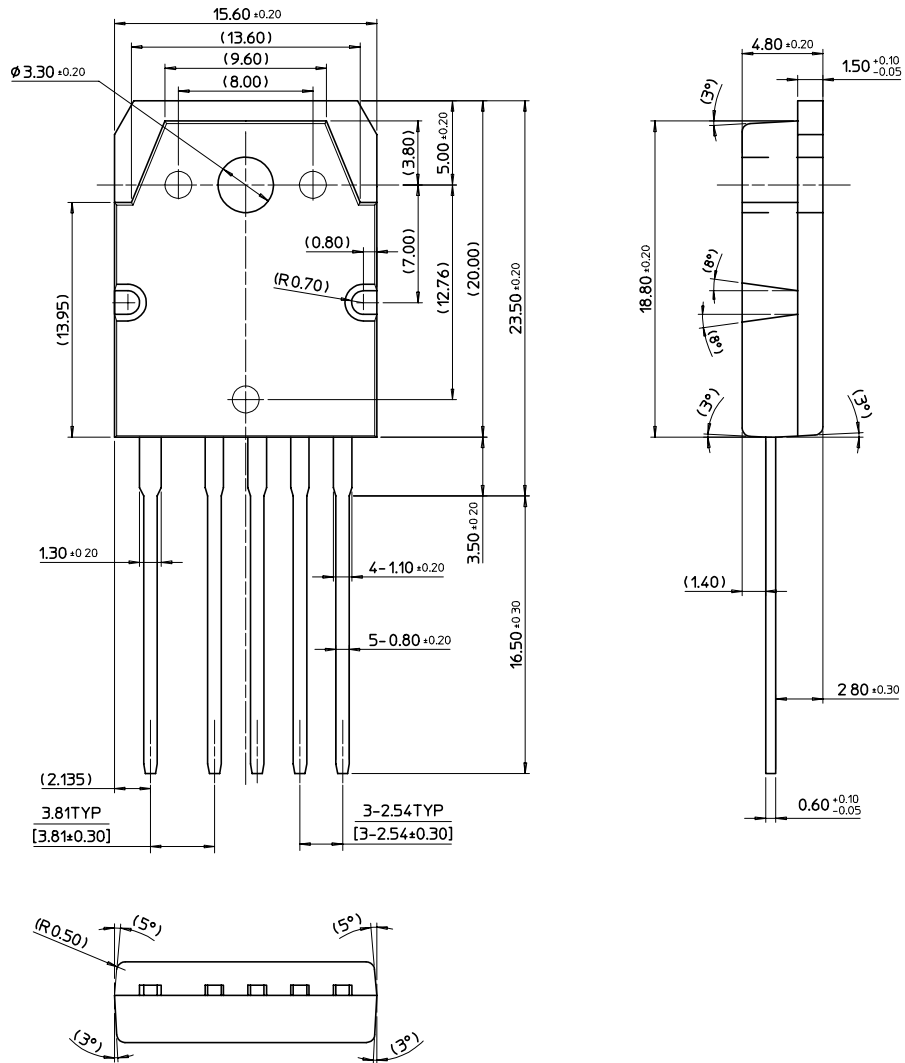

Ordering Information

Product Number	Package	Rating	Fosc
FS7M0880TU	TO-3P-5L	800V, 8A	67kHz
FS7M0880YDTU	TO-3P-5L(Forming)		

TU : Non Forming Type

YDTU : Forming type

DISCLAIMER

FAIRCHILD SEMICONDUCTOR RESERVES THE RIGHT TO MAKE CHANGES WITHOUT FURTHER NOTICE TO ANY PRODUCTS HEREIN TO IMPROVE RELIABILITY, FUNCTION OR DESIGN. FAIRCHILD DOES NOT ASSUME ANY LIABILITY ARISING OUT OF THE APPLICATION OR USE OF ANY PRODUCT OR CIRCUIT DESCRIBED HEREIN; NEITHER DOES IT CONVEY ANY LICENSE UNDER ITS PATENT RIGHTS, NOR THE RIGHTS OF OTHERS.

LIFE SUPPORT POLICY

FAIRCHILD'S PRODUCTS ARE NOT AUTHORIZED FOR USE AS CRITICAL COMPONENTS IN LIFE SUPPORT DEVICES OR SYSTEMS WITHOUT THE EXPRESS WRITTEN APPROVAL OF THE PRESIDENT OF FAIRCHILD SEMICONDUCTOR CORPORATION. As used herein:

1. Life support devices or systems are devices or systems which, (a) are intended for surgical implant into the body, or (b) support or sustain life, and (c) whose failure to perform when properly used in accordance with instructions for use provided in the labeling, can be reasonably expected to result in a significant injury of the user.
2. A critical component in any component of a life support device or system whose failure to perform can be reasonably expected to cause the failure of the life support device or system, or to affect its safety or effectiveness.