

isc Silicon NPN Power Transistor

BU2508AF

DESCRIPTION

- Collector-Emitter Sustaining Voltage-
: $V_{CEO(SUS)} = 700V$ (Min)
- High Switching Speed

APPLICATIONS

- Designed for use in horizontal deflection circuits of color TV receivers.

ABSOLUTE MAXIMUM RATINGS($T_a=25^{\circ}C$)

SYMBOL	PARAMETER	VALUE	UNIT
V_{CES}	Collector- Emitter Voltage($V_{BE} = 0$)	1500	V
V_{CEO}	Collector-Emitter Voltage	700	V
V_{EBO}	Emitter-Base Voltage	7.5	V
I_C	Collector Current- Continuous	8	A
I_{CM}	Collector Current-Peak	15	A
I_B	Base Current- Continuous	4	A
I_{BM}	Base Current-Peak	6	A
P_C	Collector Power Dissipation @ $T_C=25^{\circ}C$	45	W
T_J	Junction Temperature	150	$^{\circ}C$
T_{stg}	Storage Temperature Range	-65~150	$^{\circ}C$

SYMBOL	PARAMETER	MAX	UNIT
$R_{th\ j-c}$	Thermal Resistance, Junction to Case	2.5	$^{\circ}C/W$

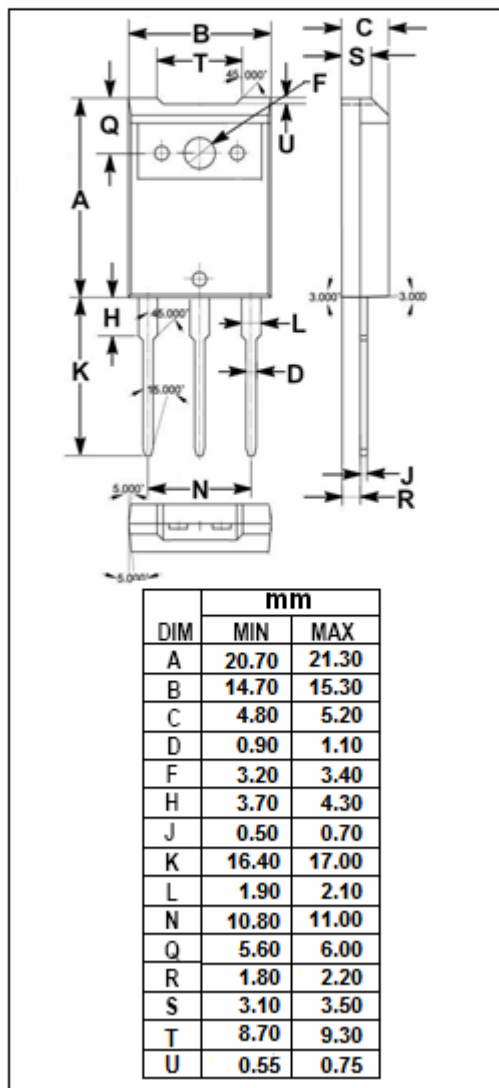
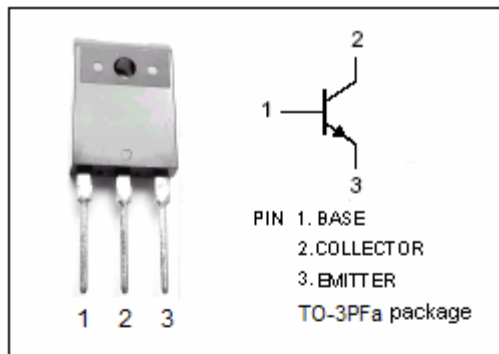

isc Silicon NPN Power Transistor

BU2508AF

ELECTRICAL CHARACTERISTICS

 $T_C=25^{\circ}\text{C}$ unless otherwise specified

SYMBOL	PARAMETER	CONDITIONS	MIN	TYP.	MAX	UNIT
$V_{CEO(SUS)}$	Collector-Emitter Sustaining Voltage	$I_C=100\text{mA}$; $I_B=0, L=25\text{mH}$	700			V
$V_{(BR)EBO}$	Emitter-Base Breakdown Voltage	$I_E=1\text{mA}$; $I_C=0$	7.5			V
$V_{CE(sat)}$	Collector-Emitter Saturation Voltage	$I_C=4.5\text{A}$; $I_B=1.1\text{A}$			1.0	V
$V_{BE(sat)}$	Base-Emitter Saturation Voltage	$I_C=4.5\text{A}$; $I_B=1.7\text{A}$			1.1	V
I_{CES}	Collector Cutoff Current	$V_{CE}=1500\text{V}$; $V_{BE}=0$ $V_{CE}=1500\text{V}$; $V_{BE}=0$; $T_C=125^{\circ}\text{C}$			1.0 2.0	mA
I_{EBO}	Emitter Cutoff Current	$V_{EB}=7.5\text{V}$; $I_C=0$			1.0	mA
h_{FE-1}	DC Current Gain	$I_C=0.1\text{A}$; $V_{CE}=5\text{V}$		13		
h_{FE-2}	DC Current Gain	$I_C=4.5\text{A}$; $V_{CE}=1\text{V}$	4		7	
C_{OB}	Output Capacitance	$I_E=0$; $V_{CB}=10\text{V}$; $f_{\text{test}}=1\text{MHz}$		80		pF

Switching times

t_{stg}	Storage Time	$I_C=4.5\text{A}$, $I_{B(end)}=1.1\text{A}$; $L_B=6\mu\text{H}$ $-V_{BB}=4\text{V}$; $(-dI_B/dt=0.6\text{A}/\mu\text{s})$			6.0	μs
t_f	Fall Time				0.6	μs

isc Silicon NPN Power Transistor

BU2508AF

h_{FE} - I_C Characteristics

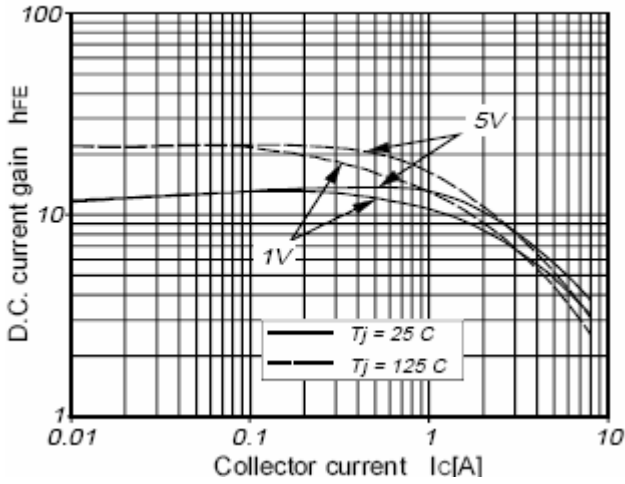

$V_{CE(sat)}$ - I_C Characteristics

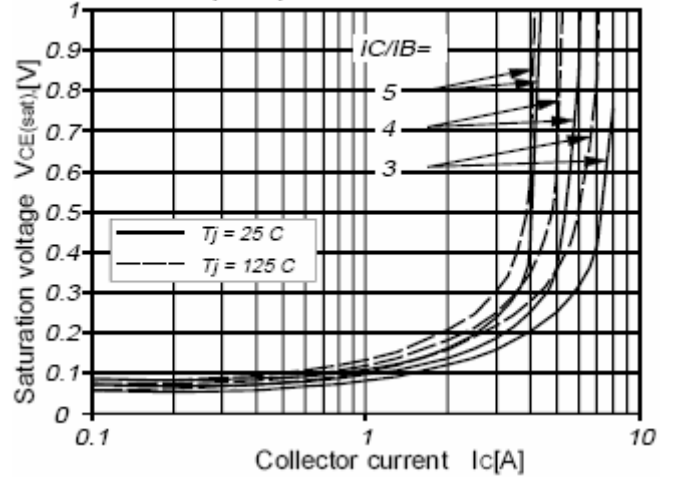

$V_{BE(sat)}$ - I_C Characteristics

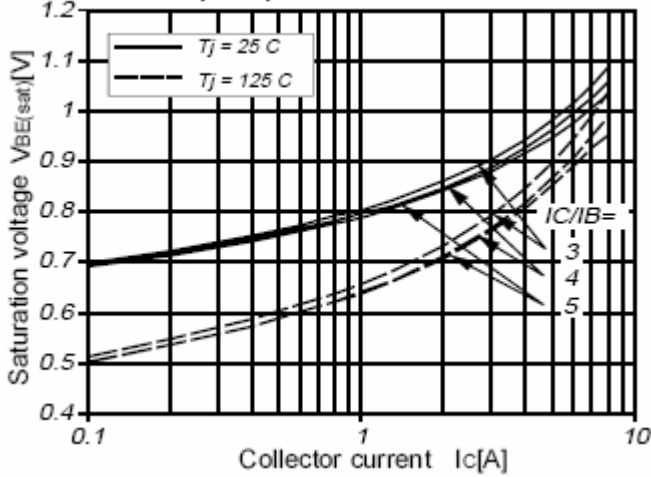

Safe Operating Area

