

isc Silicon NPN Power Transistor

BU2508DF

DESCRIPTION

- Collector-Emitter Sustaining Voltage-
: $V_{CEO(SUS)} = 700V$ (Min)
- High Switching Speed
- Built-in Damper Diode

APPLICATIONS

- Designed for use in horizontal deflection circuits of color TV receivers.

ABSOLUTE MAXIMUM RATINGS($T_a=25^{\circ}C$)

SYMBOL	PARAMETER	VALUE	UNIT
V_{CES}	Collector- Emitter Voltage($V_{BE} = 0$)	1500	V
V_{CEO}	Collector-Emitter Voltage	700	V
V_{EBO}	Emitter-Base Voltage	7.5	V
I_C	Collector Current- Continuous	8	A
I_{CM}	Collector Current-Peak	15	A
I_B	Base Current- Continuous	4	A
I_{BM}	Base Current-Peak	6	A
P_C	Collector Power Dissipation @ $T_C=25^{\circ}C$	45	W
T_J	Junction Temperature	150	$^{\circ}C$
T_{stg}	Storage Temperature Range	-65~150	$^{\circ}C$

SYMBOL	PARAMETER	MAX	UNIT
$R_{th\ j-c}$	Thermal Resistance, Junction to Case	2.8	$^{\circ}C/W$

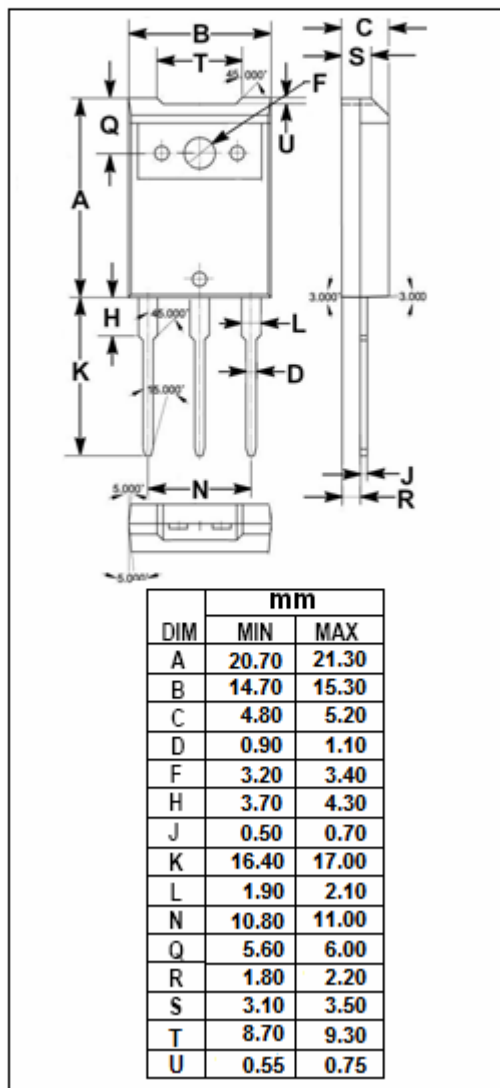
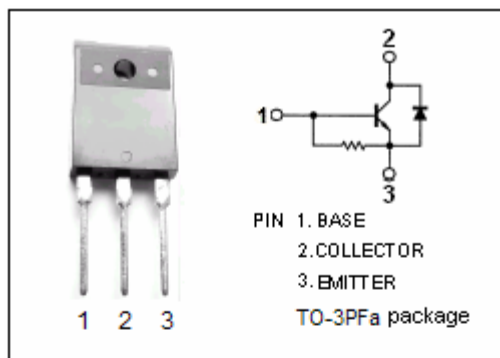

isc Silicon NPN Power Transistor

BU2508DF

ELECTRICAL CHARACTERISTICS

T_C=25°C unless otherwise specified

SYMBOL	PARAMETER	CONDITIONS	MIN	TYP.	MAX	UNIT
V _{CEO(SUS)}	Collector-Emitter Sustaining Voltage	I _C = 100mA ; I _B = 0, L= 25mH	700			V
V _{(BR)EBO}	Emitter-Base Breakdown Voltage	I _E = 600mA; I _C = 0	7.5			V
V _{CE(sat)}	Collector-Emitter Saturation Voltage	I _C = 4.5A; I _B = 1.12A			1.0	V
V _{BE(sat)}	Base-Emitter Saturation Voltage	I _C = 4.5A; I _B = 1.7A			1.1	V
I _{CES}	Collector Cutoff Current	V _{CE} = 1500V ; V _{BE} = 0 V _{CE} = 1500V ; V _{BE} = 0; T _C =125°C			1.0 2.0	mA
I _{EBO}	Emitter Cutoff Current	V _{EB} = 7.5V ; I _C = 0		227		mA
h _{FE-1}	DC Current Gain	I _C = 1A ; V _{CE} = 5V		13		
h _{FE-2}	DC Current Gain	I _C = 4.5A ; V _{CE} = 1V	4		7	
V _{ECF}	C-E Diode Forward Voltage	I _F = 4.5A			2.0	V
C _{OB}	Output Capacitance	I _E = 0; V _{CB} = 10V; f _{test} = 1MHz		80		pF

Switching times

t _{stg}	Storage Time	I _C = 4.5A , I _{B(end)} = 1.1A; L _B = 6 μ H -V _{BB} = 4V; (-dI _B /dt= 0.6A/ μ s)			6.0	μ s
t _f	Fall Time				0.6	μ s

isc Silicon NPN Power Transistor

BU2508DF

