

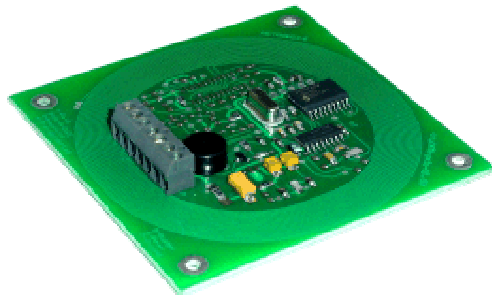

Technical Data Sheet

CTU-232

Ctu232-doc-02.04
In reference to ctu005-c-01.02



Contents

Contents 2
Introduction..... 3
Specifications..... 3
Pin description 4
Module PCB dimensions..... 4
Frame format for serial transmission 5
CRC value calculation..... 6
The Unique transponder description 7

Introduction

The CTU-232 module operates on principle of the contact less unique data acquiring from UNIQUE (RFID) transponders. Data is processed suitably and next transmitted in serial form to the master unit. Additionally indication LED can be connected to the reader signaling successful information reading from transponder and power-on indicating LED. Buzzer located on board beeps at the moment of reading.

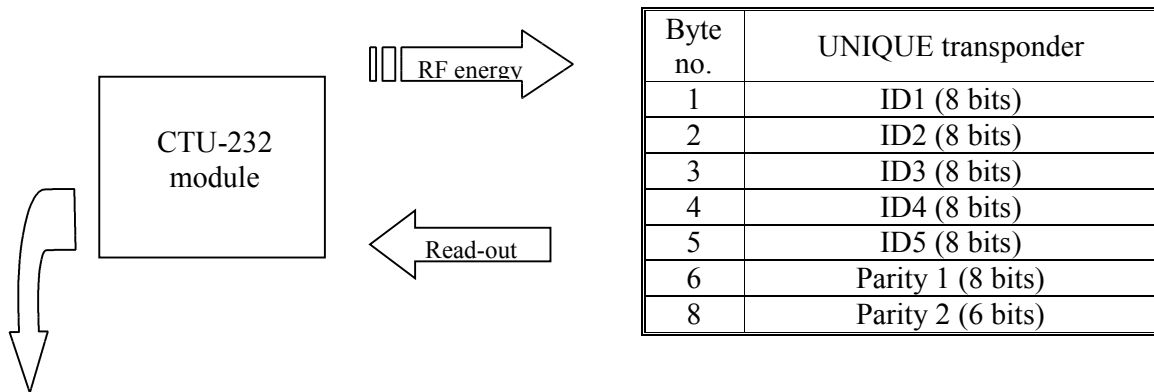

Response received:

Module address	Frame width	Response	ID	Operation code	CRCH,CRCL
01	0b	01	ID1...ID5	ff	xx xx

Specifications

- Supply voltage Vdd..... 8...13 V
- Supply current..... 5...55 mA
- Module rated operating radio frequency..... 125 kHz
- Modulation type of data received from transponder..... Manchester
- Baud rate of data received from transponder..... RF/64 (1953 b/s)
- Output current capacity: transponder Rx/Tx LED..... 15 mA
- Transponder read-out distance..... 8...10 cm
- Maximum read-out frequency..... 2 transponder read-outs/sec
- Data transmission parameters to the master unit..... 9600 b/s, 8 data bits 1 stop bit, no parity bit, with voltage levels RS232C compatible

Pin description

1-Rx	non connected
2-Tx	serial data output
3-PowerLed	auxiliary LED output for the power-on status signaling
4-TransponderLed	auxiliary LED output for the successful transponder read-out signaling
5-Buzzer	buzzer auxiliary output
6-Power	plus of supply voltage V_{pp}
7-Ground	earth (minus) of supply voltage, it is a common output of serial data and for LED connection

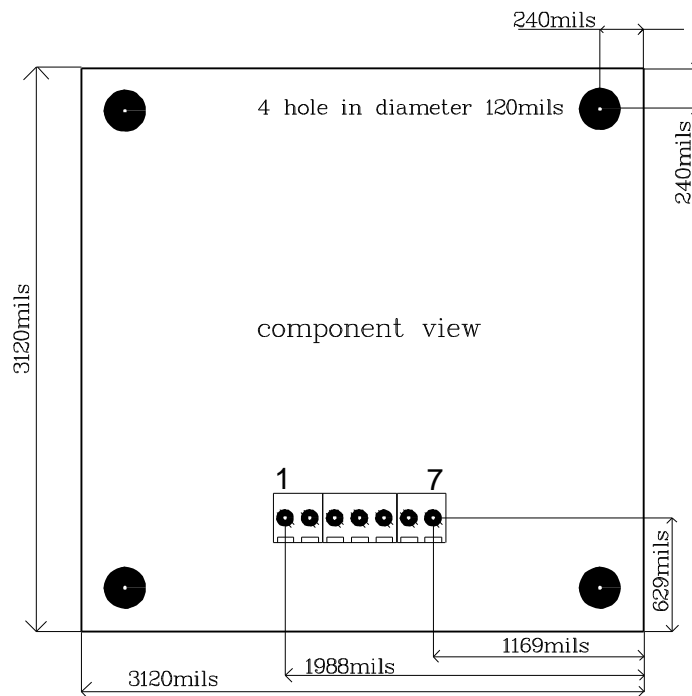
Module PCB dimensions

Frame format for serial transmission

Module address	Frame width	Response	Data	Operation code	CRCH	CRCL
1 byte	1 byte	1 byte	n bytes	1 byte	1 byte	1 byte

Where during read-out from transponder:

Module address - 0x01 always

Frame width – total number of response frame bytes = 0x0b

Response = 0x01

Data - ID1...5 – transponder ID (5 bytes)

Operation code i – 0xff

CRCH, CRCL - CRC16 MSByte and LSByte respectively

During ca. 1 sec, after turning on the power, CTU-232 reader sends software version number. This number is encoded in compliance with transmission format mentioned above, by the same time:

Frame width – total number of response frame bytes

Response = 0xff

Data – number of software version number written in ASCII code.



The reader can be tested with free of charge FRAMER software tool, which makes work with frames easier.

CRC value calculation

The CRC value is calculated from equation $x^{16}+x^{12}+x^5+1$ with initial value equal to 0x0000. This value is calculated in virtue of all the bytes except of CRCH and CRCL.

Example of calculation of CRC value, written in C language:

```
void LiczCRC2(unsigned char *ZAdr, unsigned short *DoAdr, unsigned char Ile)
{
  int i,NrBajtu;
  unsigned short C;
  *DoAdr=0;
  for (NrBajtu=1;NrBajtu<=Ile;NrBajtu++,ZAdr++)
  {
    C=((*DoAdr>>8)^*ZAdr)<<8;
    for (i=0;i<8;i++)
      if (C&0x8000) C=(C<<1)^0x1021;
      else C=C<<1;
    *DoAdr=C^(*DoAdr<<8);
  }
}
```

where:

*Zadr - the data first byte flag
 Ile - number of bytes used for calculations the CRC value (in this case the number is equal to 9).
 *DoAdr - flag of calculated CRC value (two bytes CRCH and CRCL)

The Unique transponder description

Unique transponder (EM Microelectronic standard – Marin SA, H4102) comprises 5 bytes with laser written unique ID number. Correctness of read-out data is protected with parities written in 2 subsequent bytes. It gives 40 bytes of unique ID number. Owing to the CTU-232 reader, the transponder reads the ID number, verifies read-out correctness automatically and next sends this number to master unit via serial interface port.

Byte no.	Unique transponder
1	ID1 (8 bits)
2	ID2 (8 bits)
3	ID3 (8 bits)
4	ID4 (8 bits)
5	ID5 (8 bits)
6	Parity 1 (8 bits)
8	Parity 2 (6 bits)

Overview of latest NETRONIX products is available on website:
<http://www.netronix.pl/>