



TO-92 Plastic-Encapsulate Transistors

MPS2222A TRANSISTOR (NPN)

FEATURE

- Complementary NPN Type available (MPS2907A)

MAXIMUM RATINGS (T_a=25°C unless otherwise noted)

Symbol	Parameter	Value	Unit
V _{CBO}	Collector-Base Voltage	75	V
V _{CEO}	Collector-Emitter Voltage	40	V
V _{EBO}	Emitter-Base Voltage	6	V
I _C	Collector Current -Continuous	600	mA
P _C	Collector Power Dissipation	625	mW
T _J	Junction Temperature	150	°C
T _{stg}	Storage Temperature	-55-150	°C

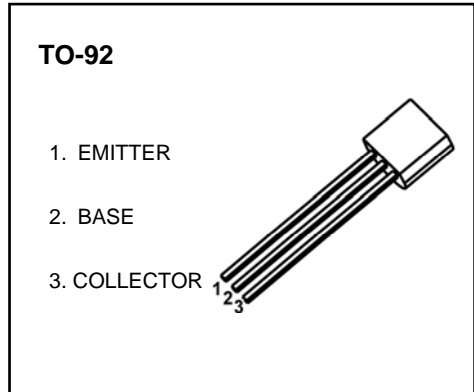

ELECTRICAL CHARACTERISTICS (T_a=25°C unless otherwise specified)

Parameter	Symbol	Test conditions	Min	Max	Unit
Collector-base breakdown voltage	V _{(BR)CBO}	I _C = 10uA , I _E =0	75		V
Collector-emitter breakdown voltage	V _{(BR)CEO}	I _C = 10mA , I _B =0	40		V
Emitter-base breakdown voltage	V _{(BR)EBO}	I _E = 10uA, I _C =0	6		V
Collector cut-off current	I _{CBO}	V _{CB} = 60V, I _E =0		10	nA
Collector cut-off current	I _{CEX}	V _{CE} = 60V, V _{EB(Off)} =3V		10	nA
Emitter cut-off current	I _{EBO}	V _{EB} = 3 V, I _C =0		100	nA
DC current gain	h _{FE(1)}	V _{CE} =10V, I _C = 150mA	100	300	
	h _{FE(2)}	V _{CE} =10V, I _C = 0.1mA	40		
	h _{FE(3)} *	V _{CE} =10V, I _C = 500mA	42		
Collector-emitter saturation voltage	V _{CE(sat)(1)} *	I _C = 500mA, I _B =50mA		0.6	V
	V _{CE(sat)(2)} *	I _C = 150mA, I _B =15mA		0.3	V
Base-emitter saturation voltage	V _{BE(sat)} *	I _C = 500mA, I _B = 50mA		1.2	V
Delay time	t _d	V _{CC} =30V, V _{EB(Off)} =-0.5V,		10	nS
Rise time	t _r	I _C =150mA, I _{B1} =15mA		25	nS
Storage time	t _s	V _{CC} =30V, I _C =150mA, I _{B1} =I _{B2} =15mA		225	nS
Fall time	t _f			60	nS
Transition frequency	f _T	V _{CE} =20V, I _C =20mA, f=100MHz	300		MHz

* pulse test

CLASSIFICATION OF h_{FE(1)}

Rank	L	H
Range	100-200	200-300