

Customer Information Sheet

DRAWING No.: R30-300XX02

SHEET 2 OF 2

IF IN DOUBT - ASK

©

NOT TO SCALE

THIRD ANGLE PROJECTION

ALL DIMENSIONS IN mm

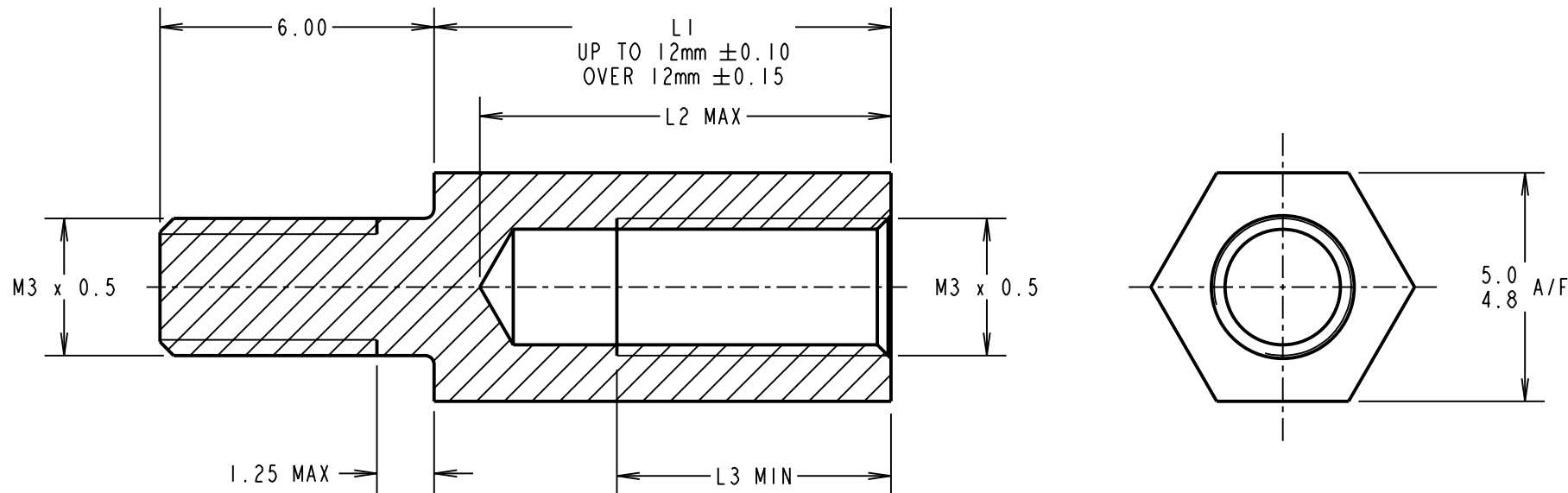

PART No.	L1	L2	L3
R30-3000402	4.00	4.0	2.00
R30-3000502	5.00	4.5	2.50
R30-3000602	6.00	5.5	3.00
R30-3000702	7.00	6.5	4.50
R30-3000802	8.00	7.5	5.50
R30-3000902	9.00	8.5	6.00
R30-3001002	10.00	9.0	6.00
R30-3001102	11.00	10.0	6.00
R30-3001202	12.00	10.0	6.00
R30-3001302	13.00	10.0	6.00
R30-3001402	14.00	10.0	6.00

PART No.	L1	L2	L3
R30-3001502	15.00	10.0	6.00
R30-3001602	16.00	10.0	6.00
R30-3001702	17.00	10.0	6.00
R30-3001802	18.00	10.0	6.00
R30-3001902	19.00	10.0	6.00
R30-3002002	20.00	10.0	6.00
R30-3002102	21.00	10.0	6.00
R30-3002202	22.00	10.0	6.00
R30-3002402	24.00	10.0	6.00
R30-3002502	25.00	10.0	6.00
R30-3002602	26.00	10.0	6.00

PART No.	L1	L2	L3
R30-3003002	30.00	10.0	6.00
R30-3003202	32.00	10.0	6.00
R30-3003402	34.00	10.0	6.00
R30-3003502	35.00	10.0	6.00
R30-3003802	38.00	10.0	6.00
R30-3004002	40.00	10.0	6.00
R30-3004502	45.00	10.0	6.00
R30-3005002	50.00	10.0	6.00
R30-3006002	60.00	10.0	6.00
R30-3008002	80.00	10.0	6.00

TOLERANCES

X. = ±1mm
 X.X = ±0.25mm
 X.XX = ±0.10mm
 X.XXX = ±0.01mm
 ANGLES = ±5°
 UNLESS STATED

MATERIAL:

BRASS CW614N M TO BS EN 12164
 (CuZn39Pb3)

FINISH:

S/AREA:

mm²

TITLE:

M3 HEXAGONAL
 MALE/FEMALE SPACER

DRAWING NUMBER:

SHT
 2
 OF
 2